

CAD FILE:

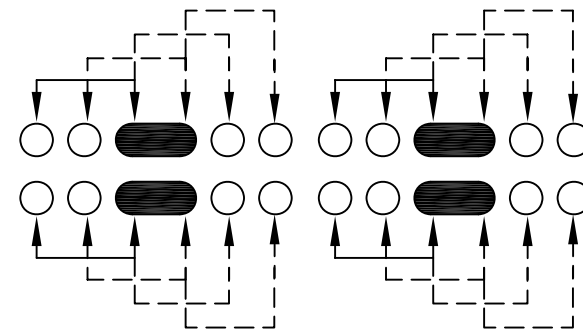

SCHEMATIC (SHORTING)

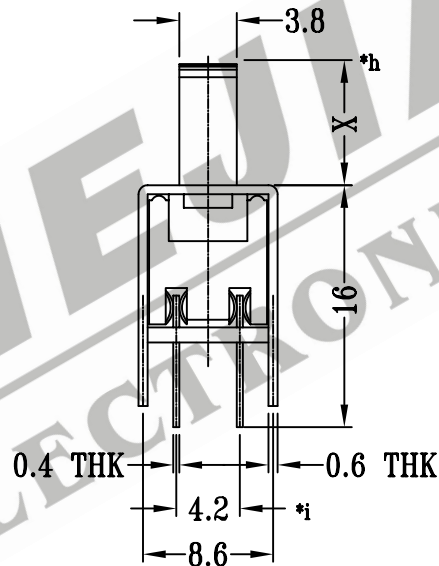
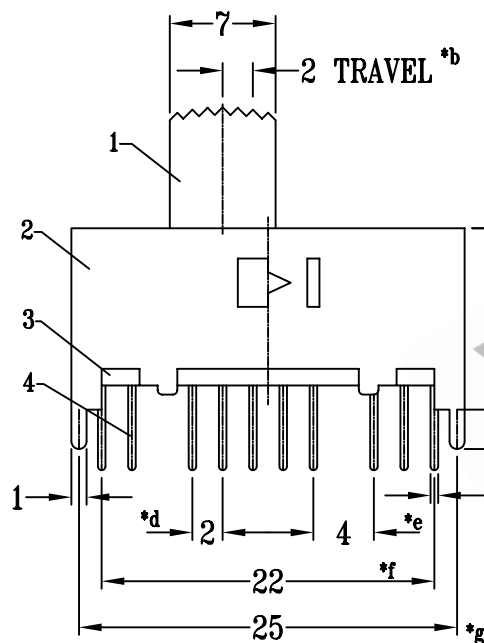
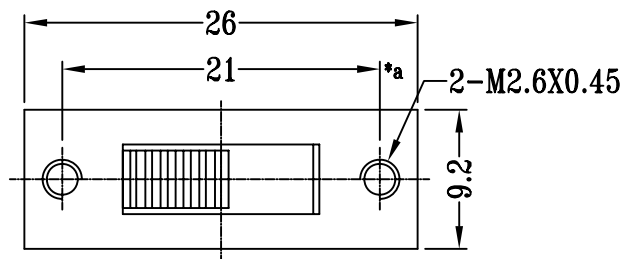
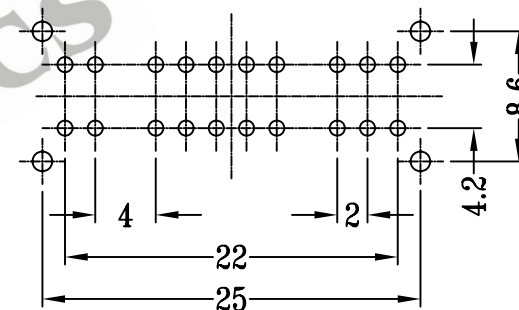

P.C.B LAYOUT

注:带"*"表示关键尺寸(9个)

NO.	PARTS	MATERIALS	Q'TY	FINISH	TOLERANCE UNLESS SPECIFIED	SHENZHEN XIEJIA ELECTRONICS CO.,LTD.				
8						TITLE : VERTICAL SLIDE SWITCH				
7	CONTACT CLIP	PBS	4	Ag CLAD	WITHIN : 1.5±0.1mm OVER : 1.5±0.2mm					UNIT : mm
6	SPRING	STEEL WIRE	1	TEMPER		ISSUE	DATE	DESCRIPTIONS OF REVISION		
5	STEEL BALL	STEEL	2	NATURAL				APPD.		
4	TERMINAL	BRASS STRIP	20	Ag PLATED OVER Ni PLATED				SCALE: 2 : 1		
3	BASE	PHENOLIC RESIN	1	BLACK				DWN.	ZHOUYU	2002-11-30
2	FRAME	STEEL STRIP	1	Ni PLATED				CHK'D	FANGYING	2002-11-30
1	KNOB	POM	1	BLACK				APPD.	KANGXINAN	2002-11-30
					ALL MATERIALS MUST BE COMPLIANT TO ROHS					